



CENTRIFUGAL SEPARATOR FILTER HYDROCYCLONES SERIES IC AND SERIE IC HF



MAIN TECHNICAL FEATURES

- Capacity ranging from 3.5 to 725 m³/h
- Minimum amount drain water
- High separation efficiency above 97% on particles having 75 micron diameter, 80% on particles having 50 micron diameter and 1.6 Kg/dm³ specific weight
- Minimal pressure loss

APPLICATIONS

- UF prefiltration systems
- Evaporative towers
- Spray nozzles protection
- Heat exchangers
- Irrigation

OPERATION

HOW IT WORKS

The water to be filtered flows through an inlet (1), welded tangential to the body, then moves downward towards the inner cone (2) as its speed increases. The centrifugal force created separates the heavier suspended solids from the water. The cleaned water hits the deflector (3) and goes back up through the outlet collector (4). Impurities are deposited below the deflector in the collection tank (5). The particles can either be discharged continuously or purged on a timed schedule via a drain hole (6)

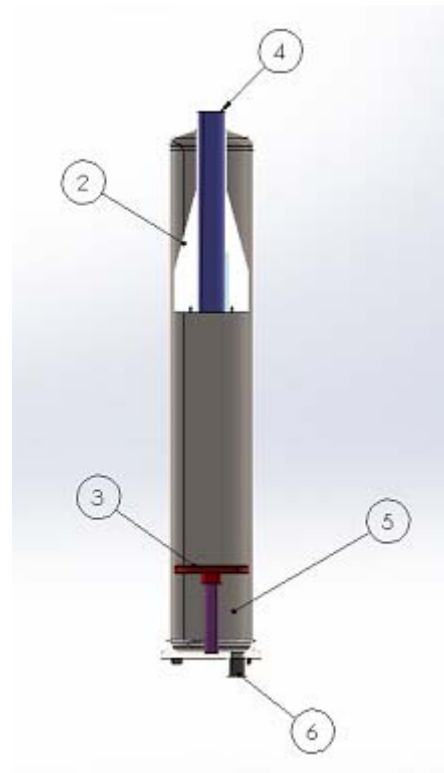
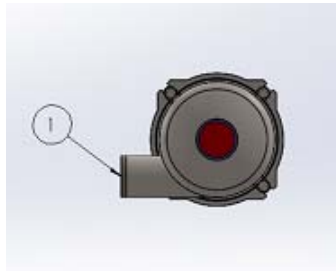

The cyclones product range features two series, the IC series with good separation performance and low head losses and the IC HF series, with excellent separation performance even up to 10 micron, but with high head loss. The diagram below shows the differences in separation efficiency between the IC and IC HF series

FILTRATION EFFICIENCY

Comparison between IC hydrocyclone and IC HF hydrocyclone

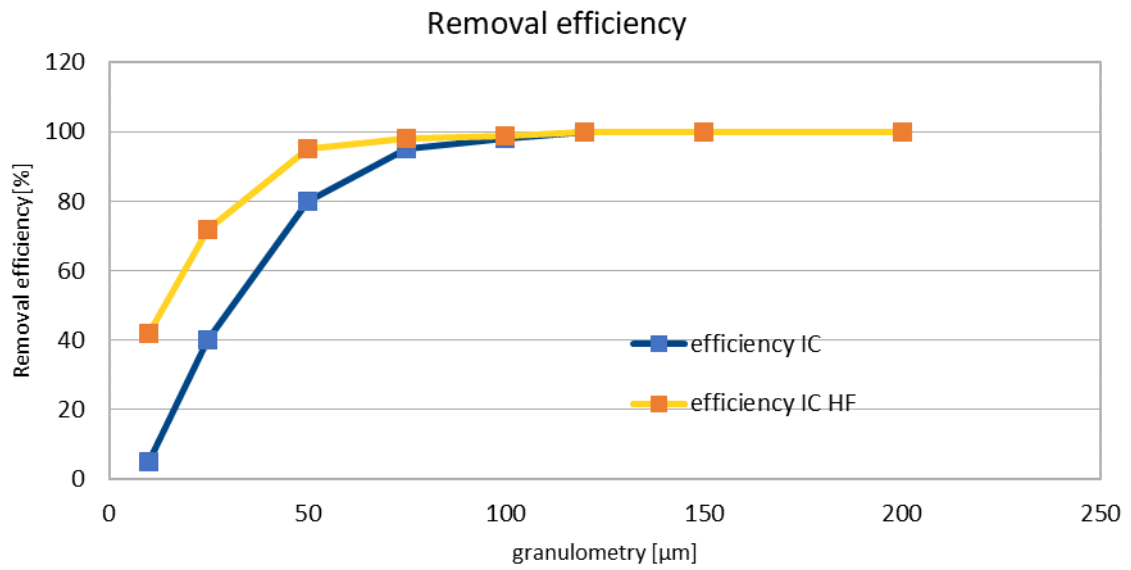

Test performed with sand having 1.6 Kg/dm³ specific weight

DIMENSIONS AND TECHNICAL DATA

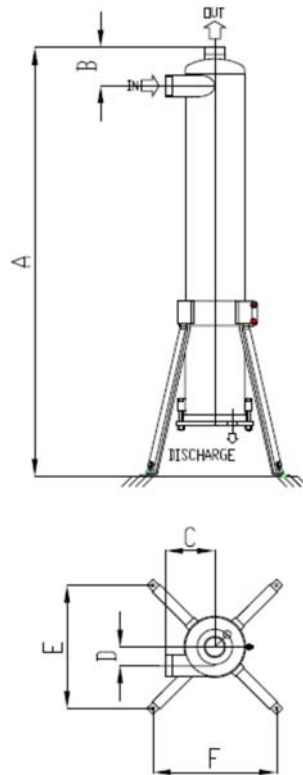

STANDARD IC HYDROCYCLONE

MODEL	IC ¾"	IC 1"	IC 1½"	IC 2"	IC 3"	IC DN100	IC DN150	IC DN200	IC DN250
Flow rate – m ³ /h With ΔP from 0.2 to 1 bar	3.5-7	6-12	11-25	18-40	32-56	52-102	91-194	186-468	295-725
In/Out	¾"M	1"M	1½"M	2"M	3"M	DN100	DN150	DN200	DN250
Drain	3/8" F	½"F	½"F	¾"F	¾"F	1"F	1½"2F	1½"2F	2"F
Maximum working pressure - Bar	10	10	10	10	10	10	10	10	10
Maximum working temperature - °C	80	80	80	80	80	80	80	80	80
MODEL	IC ¾"	IC 1"	IC 1½"	IC 2"	IC 3"	IC DN100	IC DN150	IC DN200	IC DN250
Dimensions									
A (mm)	780	935	1050	1220	1555	2300	2700	3610	3610
B (mm)	75	85	100	110	140	205	330	465	505
C (mm)	80	100	120	140	180	355	345	525	589
D (mm)	295	315	330	350	385	460	95	145	195
E (mm)	295	315	330	350	385	460	600	890	990
F (mm)	31	43	46	54	65	105	600	890	990
WEIGHT Kg	11	15	21	32	51	73	118	187	278

Technical Data are indicative and subject to change without notice

HIGH EFFICIENCY IC HF HYDROCYCLONE

MODEL	IC HF ¾"	IC HF 1"	IC HF 1"1/2	IC HF 2"	IC HF 3"	IC HF DN100	IC HF DN150
Flow rate – m ³ /h <i>With ΔP from 0.2 to 1 bar</i>	2-6	4-8	8-16	18-40	28-38	40-68	91-194
In/Out	¾"M	1"M	1"1/2M	2"M	3"M	DN100	DN150
Drain	3/8" F	½"F	½"F	¾"F	¾"F	1"F	1"1/2F
Maximum working pressure - Bar	10	10	10	10	10	10	10
Maximum working temperature - °C	60	60	60	60	60	60	60
MODEL	IC HF ¾"	IC HF 1"	IC HF 1"1/2	IC HF 2"	IC HF 3"	IC HF DN100	IC HF DN150
Dimensions							
A (mm)	780	935	1050	1220	1555	2300	2700
B (mm)	75	85	100	110	140	205	330
C (mm)	80	100	120	140	180	355	345
D (mm)	295	315	330	350	385	460	95
E (mm)	295	315	330	350	385	460	600
F (mm)	31	43	46	54	65	105	600
WEIGHT Kg	11	15	21	32	51	73	118

Technical Data are indicative and subject to change without notice

PART DESCRIPTION

COMPONENT	DESCRIPTION
Body	AISI316 – SAF2205 – SAF2507
Cover	AISI316 – SAF2205 – SAF2507
Gaskets	EPDM - NBR
Inner cone	POM
Support feet	AISI 316 S/S
Accessories (Caps and adapters)	PP - PVC

HEAD LOSS

IC - IC HF 3/4"

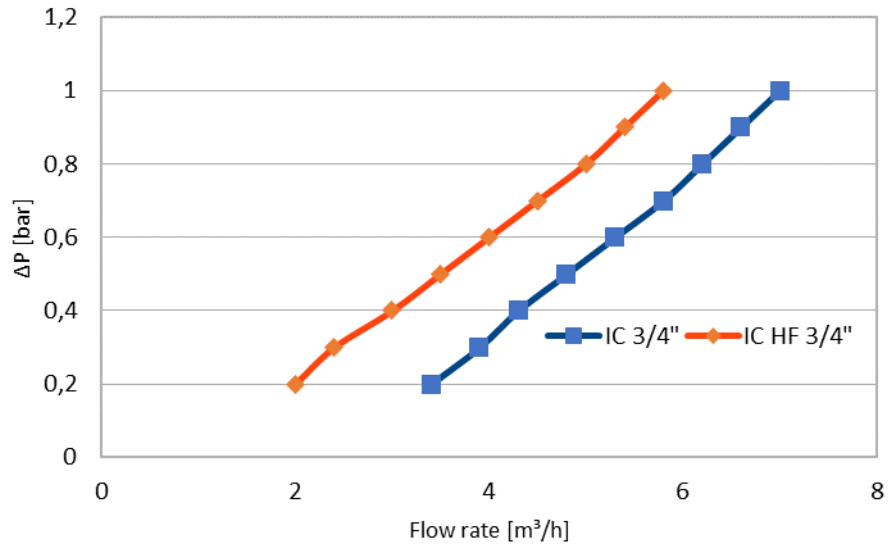

IC - IC HF 1"

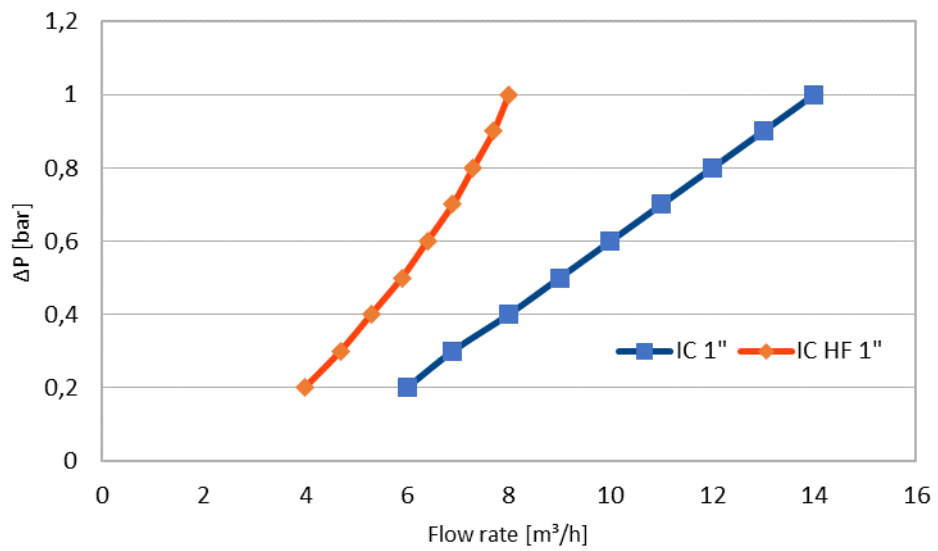

IC - IC HF 1"1/2

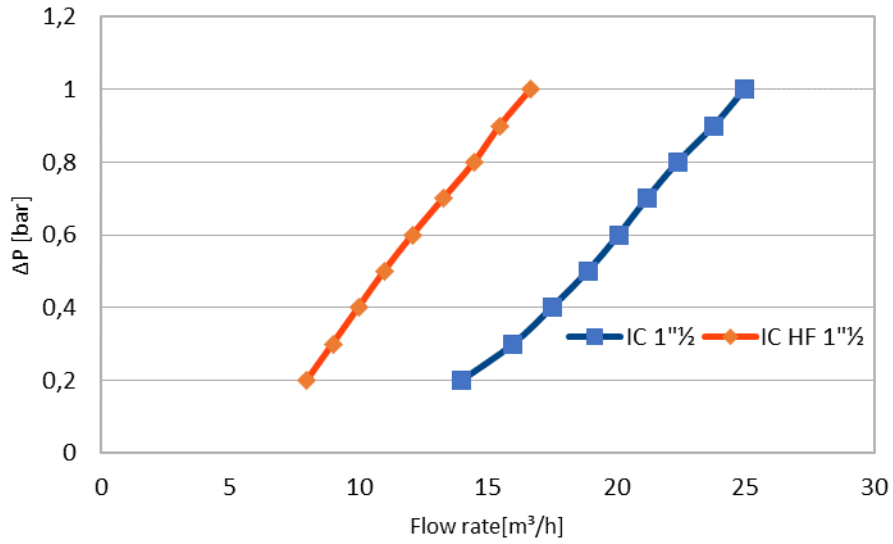

IC - IC HF 2"

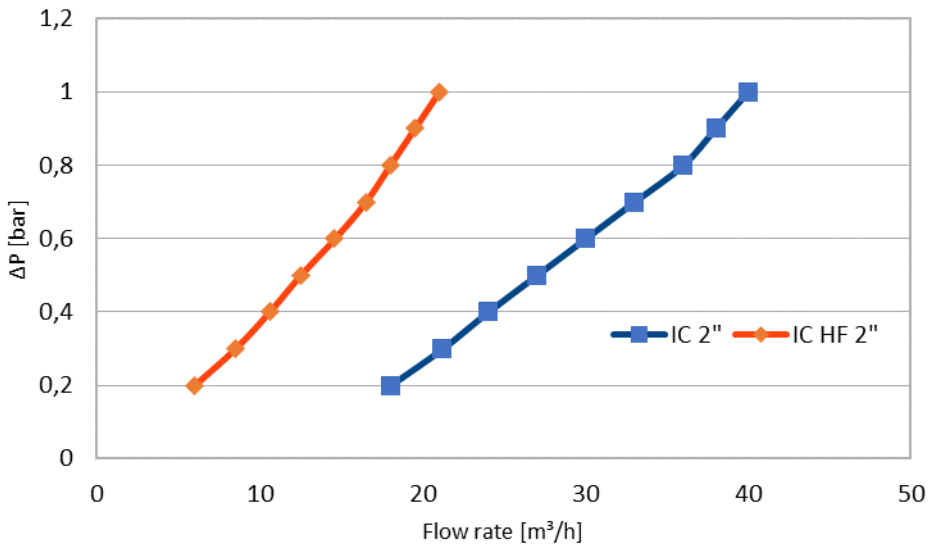

IC - IC HF 3"

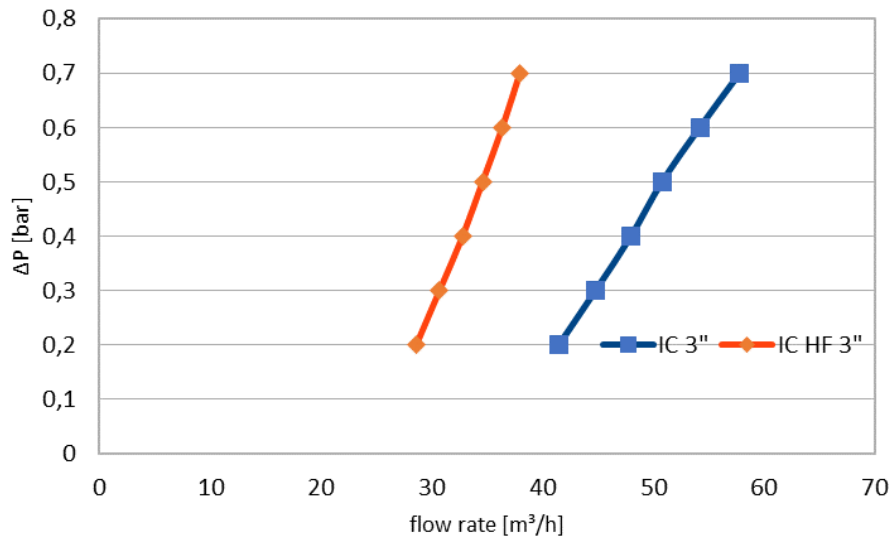

IC - IC HF DN100

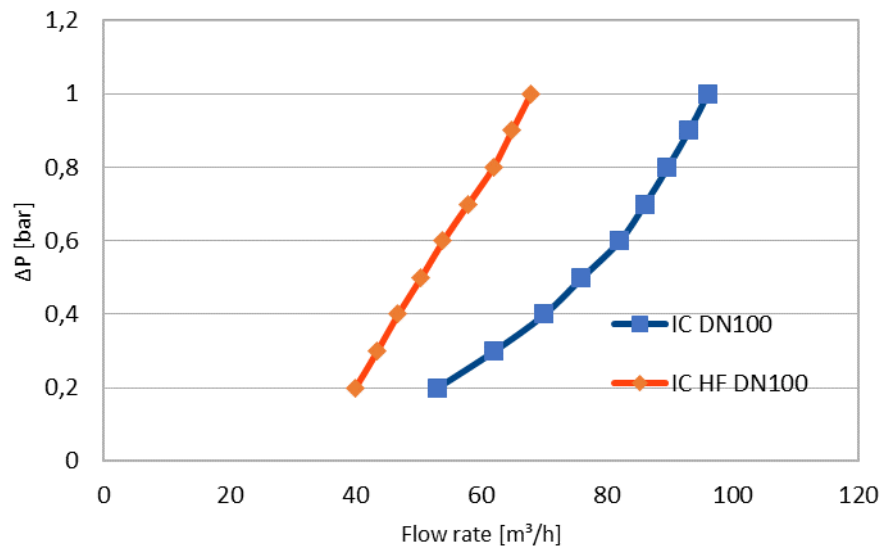

IC - IC HF DN150

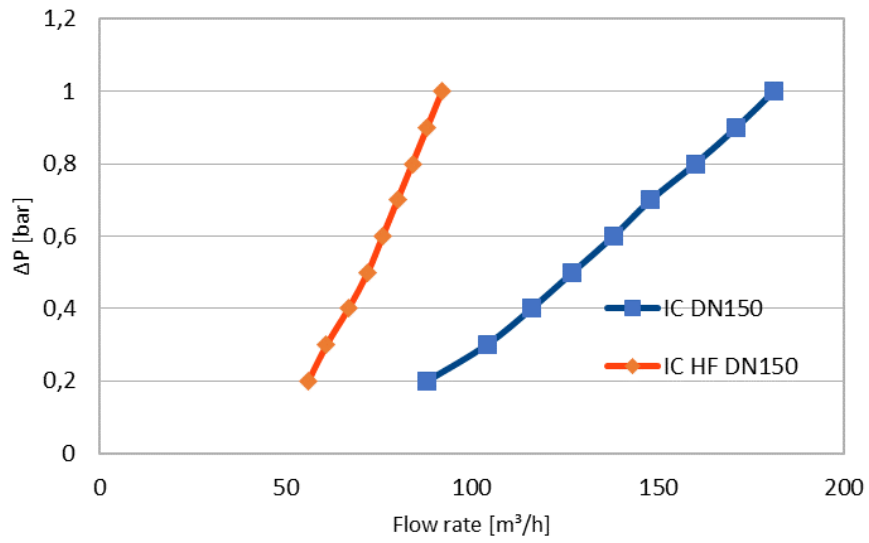

IC DN200

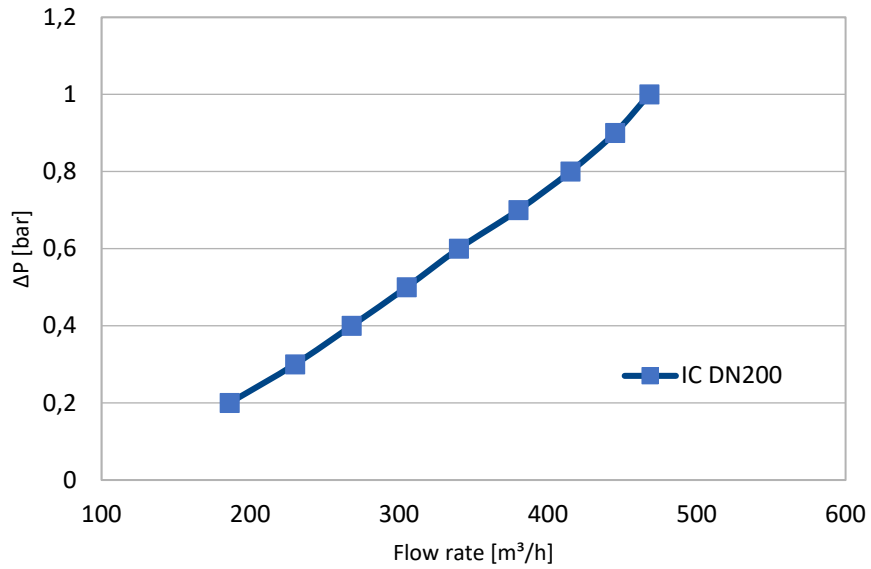

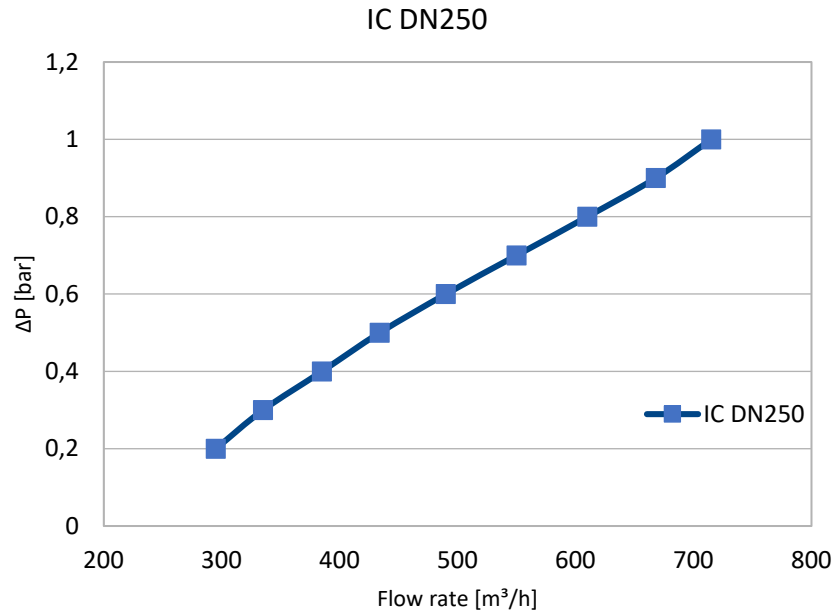

FILTER CODING TABLE

1 HYDROCYCLONE TYPE	CODE
STANDARD	IC
HIGH EFFICIENCY	ICHF

3 BODY / COVER MATERIAL	CODE
AISI 316	0316
SAF2205 (DUPLEX)	2205
SAF2507 (SUPERDUPLEX)	2507

5 AUTOMATION	CODE
PNEUMATIC DISCHARGE	C
HYDRAULIC DISCHARGE	I
NONE	0

2 APPLICATION	CODE
INDUSTRIAL	I

4 CONNECTION IN/OUT	CODE
3/4"	034
1"	001
1"1/2	112
2"	002
3"	003
DN80 PN10	080
DN100 PN10	100

STANDARD VERSION