



**SELF CLEANING FILTER MSCR – PP MICRON
WITH FILTRATION TECHNOLOGY 3D
FILTER EFFICIENCY >98%**



TECNICAL DATA:

- Continuous flow rate during back wash
- Filtration from 20 to 1 micron **SINTERED FIBER 3D**
- Maximum flow rate 15 m³/h with a single filter
- Minimum water for cleaning

APPLICATION

- Prefiltration for water treatment plants
- Cooling towers
- Heat exchangers
- Irrigation
- Protection of spray nozzle
- Sea water filtration

Ver.2022 Rev01

3D FILTERING TECHNOLOGY

The filtering element of the filtering fabric is made of AISI316 sintered fibre. This ensures high permeability with excellent filtering efficiency owed to the fabric's thickness (hence called 3D) and the diameter of the fibres.

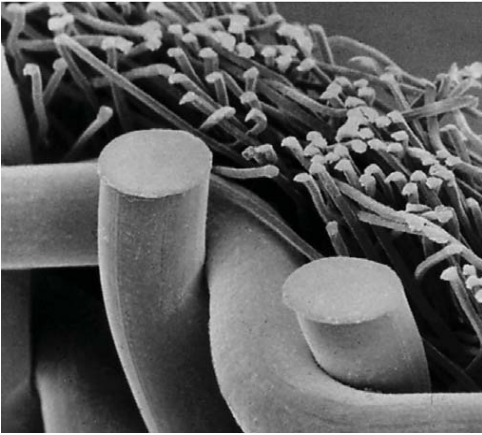

At equal surface and pressure differential, this type of construction allows retention of a much greater amount of TSS (Total Suspended Solids) compared with traditional single thread fabrics. Additionally, exposed to Delta P, the fibres are far more stable compared with single thread fabrics.

The filtering fabrics used are tested in our laboratories to assess the performance of the main filtering process. Based on performance assessments, the most suitable fabrics for the requested use are selected.

Type of fiber felt	Dirt Holding Capacity mg/m ²	Filtration speed m/h
Wire cloth AISI316 20 µm	42,545	200
Sintered fiber felt 3D AISI316 20 µm	125,465	200
Wire cloth AISI316 10 µm	38,245	150
Sintered fiber felt 3D AISI316 10 µm	102,855	150
Wire cloth AISI316 5 µm	21,112	100
Sintered fiber felt 3D AISI316 5 µm	88,623	100

The table shows load capacity data based on various filtering fabrics at various speed.

Data collected at $\Delta P = 5$ P.S.I.

DHC diagram for the data shown on the table

DHC (mg/m²) diagram

Dirt holding capacity
DHC [mg/m²]

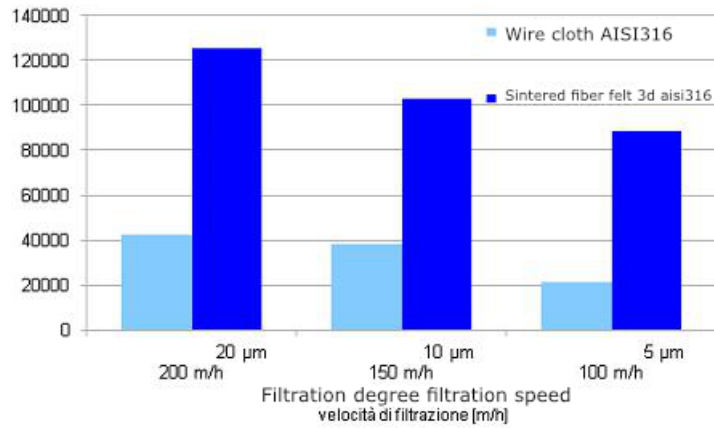
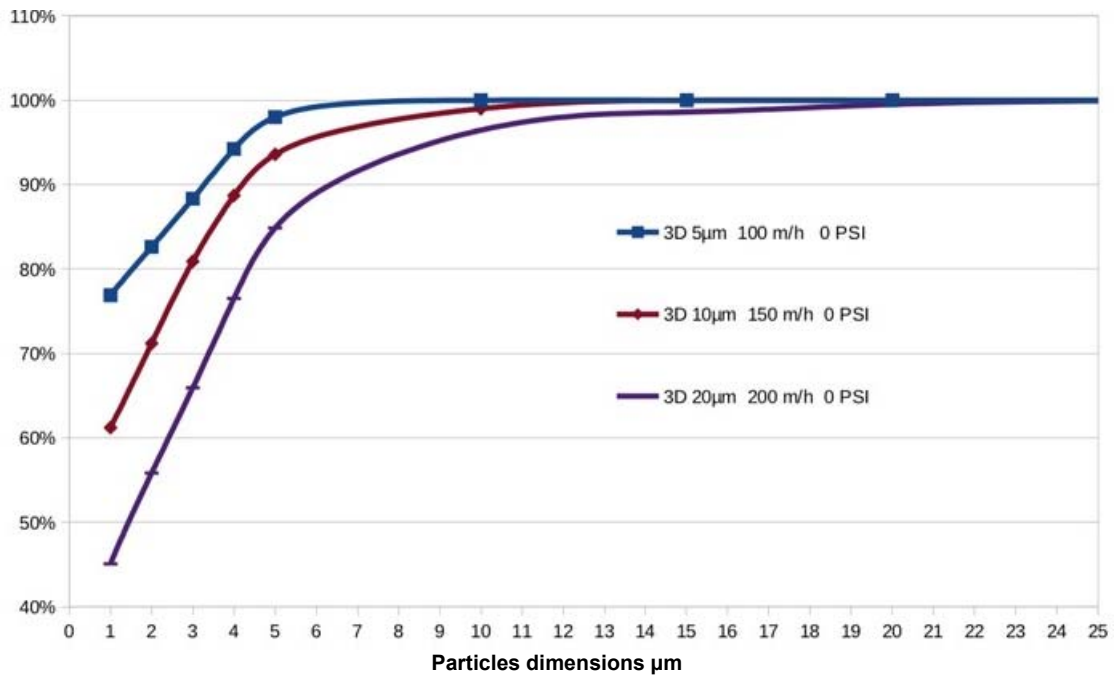

Diagram showing 3D fabrics filtering efficiency and various degrees of filtration at reference speed.

FILTRATION EFFICIENCIES



Efficiency comparison between 3D versus single thread fabrics for various degrees of filtration

Comparison between 3D fabric , monofilament fabric with 5 micron filtration degree

FILTRATION EFFICIENCIES

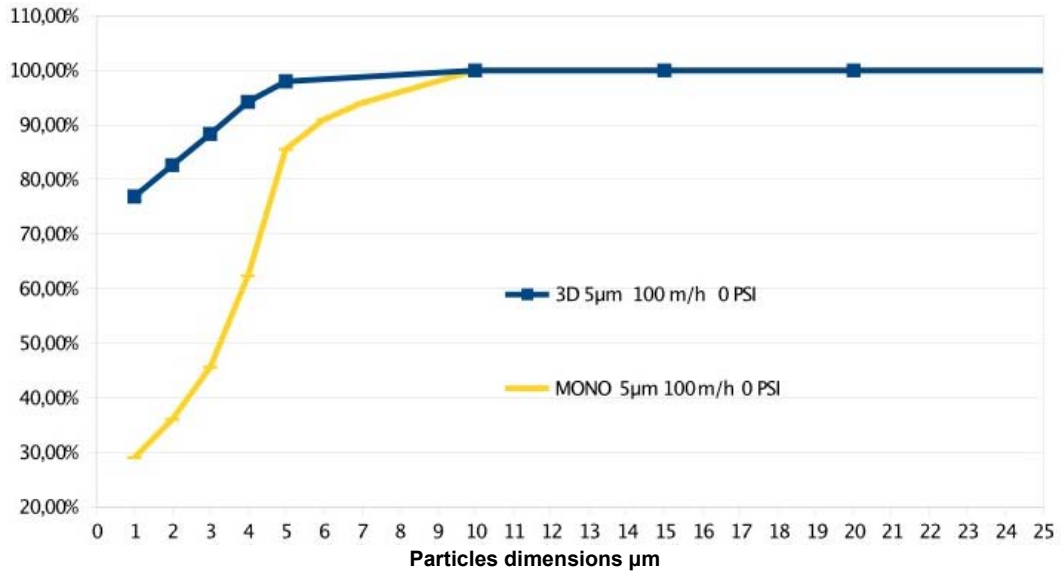

Comparison between 3D fabric, monofilament fabric with 10 micron filtration degree

FILTRATION EFFICIENCIES

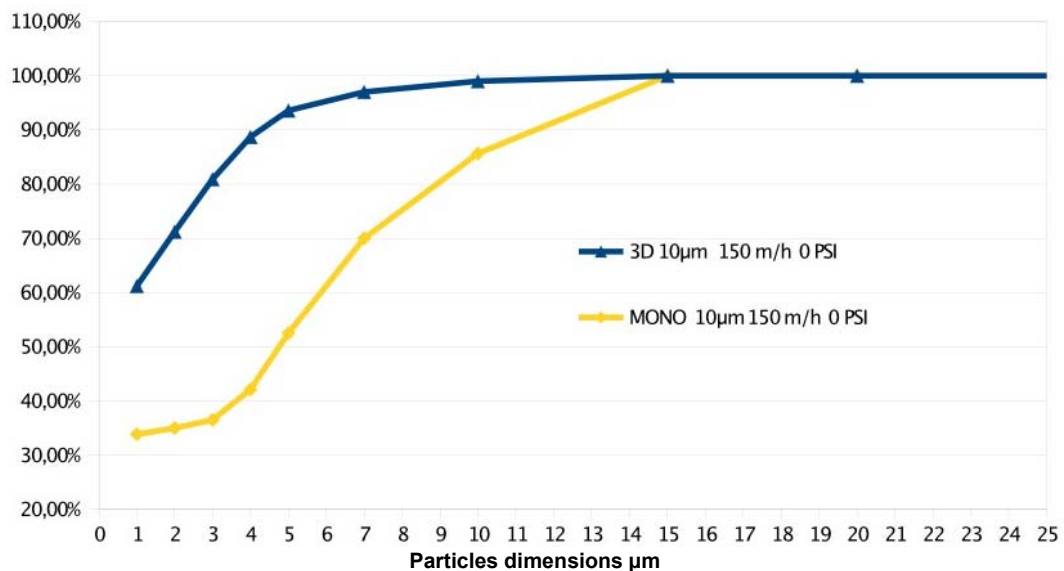

Comparison between 3D fabric , monofilament fabric with 20 micron filtration degree

FILTRATION EFFICIENCIES

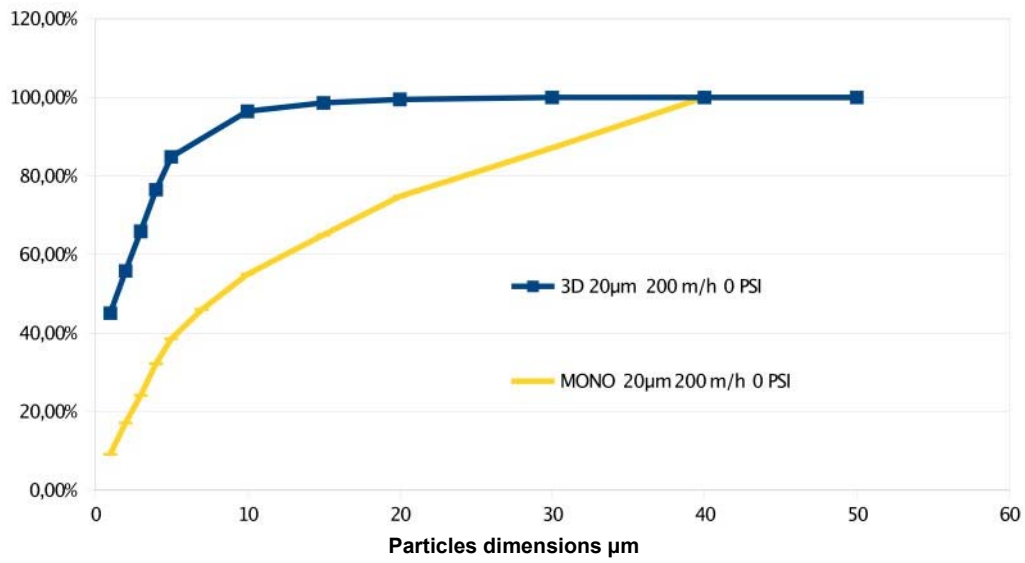

OPERATION

Water enters the filter through the IN inlet and goes through the filtering cylinder(1) from the inside to the outside. This will retain all non-deformable suspended solids that are the same size or bigger than the filtration degree installed. Filtered water leaves through the outlet pipe (OUT).

REGENERATION

The continuous settling of suspended solids inside the filtering cylinder obstructs the passage of water which results in a pressure difference (ΔP). At a preset value of ΔP (range 0.3 ÷ 1 Bar) an automatic cycle will start to clean the filter cylinder(1), this operation begins with a signal that opens the discharge valve (2) and creates communication between the suction nozzles(3) with the outside environment. At the same time, the electric motor (4) creates a rotating motion which enables the nozzles to inspect the filtering surface. Dirt is ejected through the discharge valve (2). The cleaning cycle lasts approximately 15 seconds.

CONTROL

A switchboard controls the washing phases. The signal that starts the cleaning cycle is given by a differential pressure switch. The switchboard gives an "alarm" signal in case of problems in the washing system. These signals can be sent to a pre-existing control center. The washing phase can also be controlled manually. The solenoid controlling the valve is pneumatic.

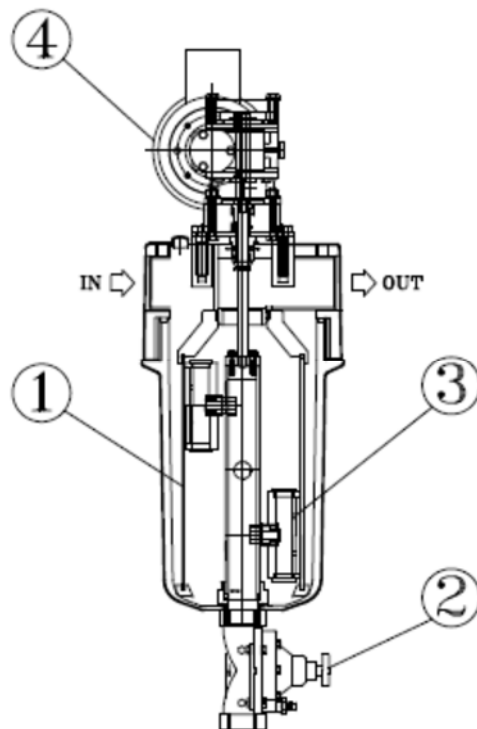

FILTER ELEMENT AND CLEANING SYSTEM

FILTRATION PHASE

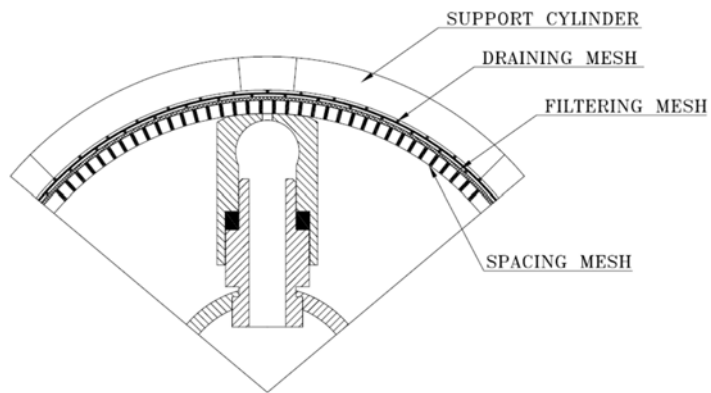

WASHING PHASE

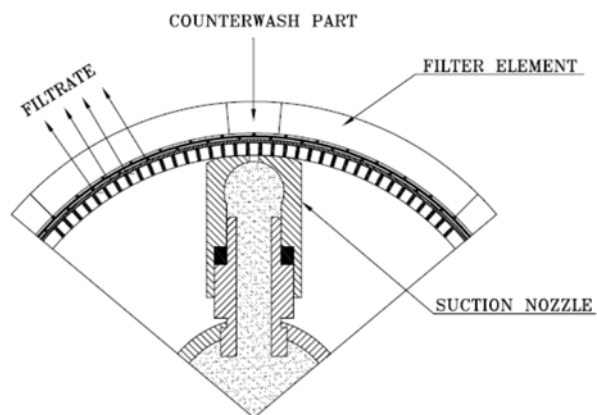

PICTURE OF FILTER INTERIOR



DIMENSIONS AND TECHNICAL DATA

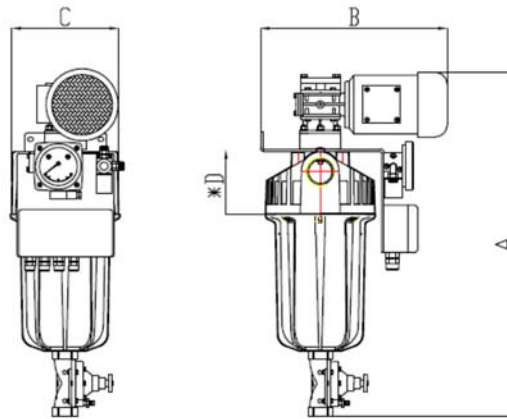

MODEL	MSCR PP -1"1/2 - 7	MSCR PP -1"1/2 - 15
Filtration area (cm ²)	700	1450
Flow rate max – m ³ /h (ΔP 0,2 Bar)	15	15
Connection In/Out	1"1/2F	1"1/2F
Discharge	1" F	1" F
1 Bar washing flow rate with mesh 125 micron - m ³ /h	2	5
Wash duration - Sec	15	15
Pressure min-max – Bar	1-6	1-6
Temperature max - °C	40	40
Power supply - Volt	220 50Hz	220 50Hz
Power required - Watt	90	180
Construction certificates	CE	CE
Maximum size of inlet particles* - mm (filtration from 20 to 1 μ m) – mm	0.2	0.2
Max total suspended solids at inlet mg/l (filtration from 20 to 10 μ m) – mg/l	20	20
Max total suspended solids at inlet mg/l (filtration from 5 to 1 μ m) – mg/l	10	10
A (mm)	610	855
B (mm)	320	320
C (mm)	190	190
D* Cartridge extraction	250	500
WEIGHT Kg	7	12

These technical data are indicative and subject to changing without notice.
 The max suspended solids at inlet is an important factor, because depending on their size distribution and their specific weight they can clog up the filter in a different way.

DESCRIPTION OF PARTS

PART	DESCRIPTION
Body	PP
Cover	PP
Connection threading	Cylindrical GAS UNI338-66
Mesh support strainer	PVC
Filtering mesh	AISI 316 3D FROM 20,15,10,5,1 Micron
Protection mesh	PP
Suction nozzle	PE
Nozzle support	PVC
Nozzle pipe	PVC
Internal seals	EPDM
Reduction unit	Aluminium and carbon steel
Electric motor	Hot-painted aluminium
Solenoid valve	Three-way aluminium
Switchboard	ABS IP55 with front display
Differential pressure switch	Aluminium with parts in contact with liquid made of AISI 316
Discharge valve	PP diaphragm with flow rate regulation
Pressure gauges	Stainless steel with 2"1/2 dial, radial connection and 0-10 Bar indication
Accessories (Plugs and adapters)	PP – PVC – AISI316

FILTERING MESH FLOW RATE TABLE FOR SCR L FILTERS (m³/h)

MODEL	20 µm AISI316	15 µm AISI316	10 µm AISI316	5 µm AISI316	1 µm AISI316
MSCR PP MICRON 1"1/2 - 7	10	9	7	5	2.5
MSCR PP MICRON 1"1/2 - 15	15	15	15	14	7

The flow rates indicated refer to a load loss of 0.2 Bar with clean, filtered water.

FILTER CODING TABLE

1 SHAPE / INSTALLATION FILTER	CODE
L / VERTICAL	MSCRM

3 MATERIAL BODY AND COVER	CODE
POLYPROPYLENE	PP

5 FILTER ELEMENT SIZE	CODE
7	07
15	15

7 FILTERING FABRIC MATERIAL	CODE
AISI316 3D	1

9 FILTRATION DEGREE	CODE
20	20
15	15
10	10
5	05
1	01

2 APPLICATION	CODE
INDUSTRIAL	I

4 CONNECTION IN/OUT	CODE
1"1/2	112

6 BASKET MATERIAL	CODE
PVC-U	1

8 PILOT DISCHARGE VALVE	CODE
PNEUMATIC	1
HYDRAULIC	2

10 AUTOMATION	CODE
CONTROL PANEL + DIFF. SWITCH	C
NESSUNA	0

STANDARD VERSION