



SUCTION SCANNER SELF CLEANING FILTER SERIES SCR L M

3D FILTERING TECHNOLOGY

FILTER EFFICIENCY >98%

MAIN TECHNICAL CHARACTERISTICS:

- Continuous flow including during washing phase
- Filtration degree from 20 to 5 micron
- Maximum flow rate 260 m³/h with a single filter
- Minimum quantity of water at discharge

APPLICAZIONI

- Pre-filtration in UF systems
- Evaporation towers
- Spray nozzle protection
- Heat exchangers
- Sea water



Ver.2022 Rev00

ELFI srl

Via Scodoncello 41/E 43044 Collecchio (PR)
Tel 0521806846

3D FILTERING TECHNOLOGY

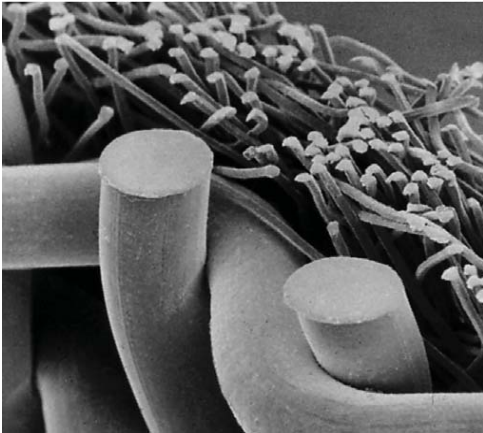

The filtering element of the filtering fabric is made of AISI316 sintered fibre. This ensures high permeability with excellent filtering efficiency owed to the fabric's thickness (hence called 3D) and the diameter of the fibres.

At equal surface and pressure differential, this type of construction allows retention of a much greater amount of TSS (Total Suspended Solids) compared with traditional single thread fabrics. Additionally, exposed to Delta P, the fibres are far more stable compared with single thread fabrics.

The filtering fabrics used are tested in our laboratories to assess the performance of the main filtering process.

Based on performance assessments, the most suitable fabrics for the requested use are selected.

Type of fiber felt	Dirt Holding Capacity mg/m ²	Filtration speed m/h
Wire cloth AISI316 20 µm	42,545	200
Sintered fiber felt 3D AISI316 20 µm	125,465	200
Wire cloth AISI316 10 µm	38,245	150
Sintered fiber felt 3D AISI316 10 µm	102,855	150
Wire cloth AISI316 5 µm	21,112	100
Sintered fiber felt 3D AISI316 5 µm	88,623	100

The table shows load capacity data based on various filtering fabrics at various speed.

Data collected at $\Delta P = 5$ P.S.I.

DHC diagram for the data shown on the table

DHC (mg/m²) diagram
 Dirt holding capacity
 DHC [mg/m²]

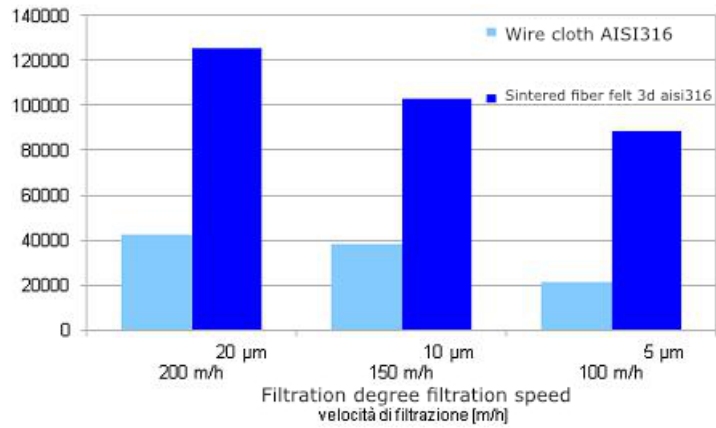
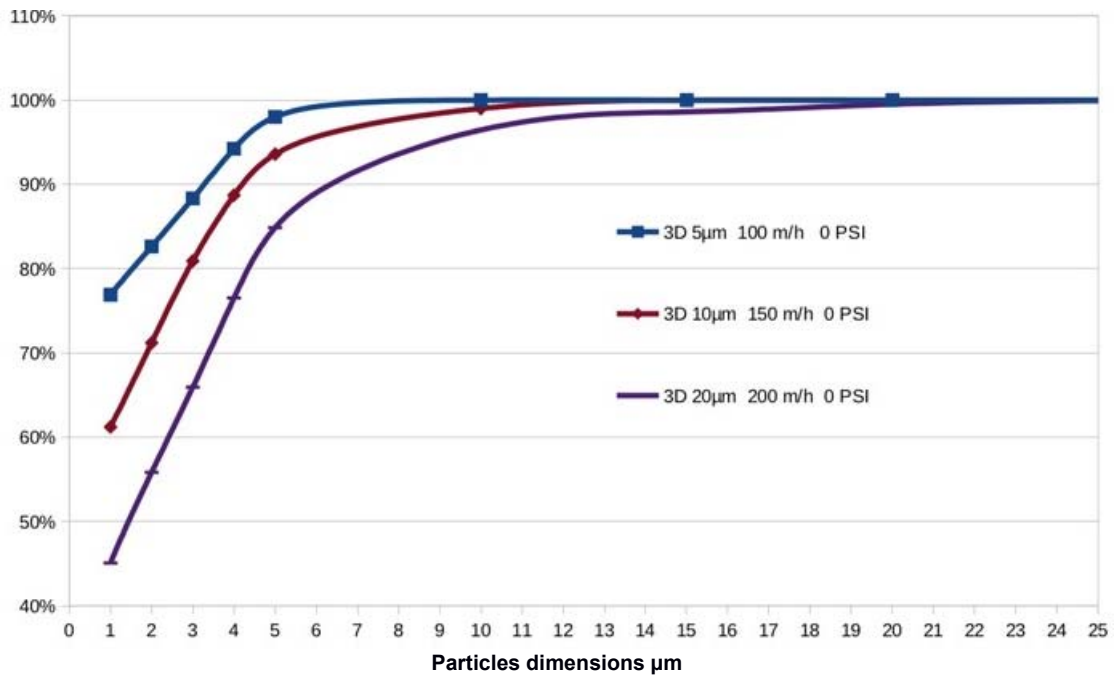

Diagram showing 3D fabrics filtering efficiency and various degrees of filtration at reference speed.

FILTRATION EFFICIENCIES



Efficiency comparison between 3D versus single thread fabrics for various degrees of filtration

Comparison between 3D fabric , monofilament fabric with 5 micron filtration degree

FILTRATION EFFICIENCIES

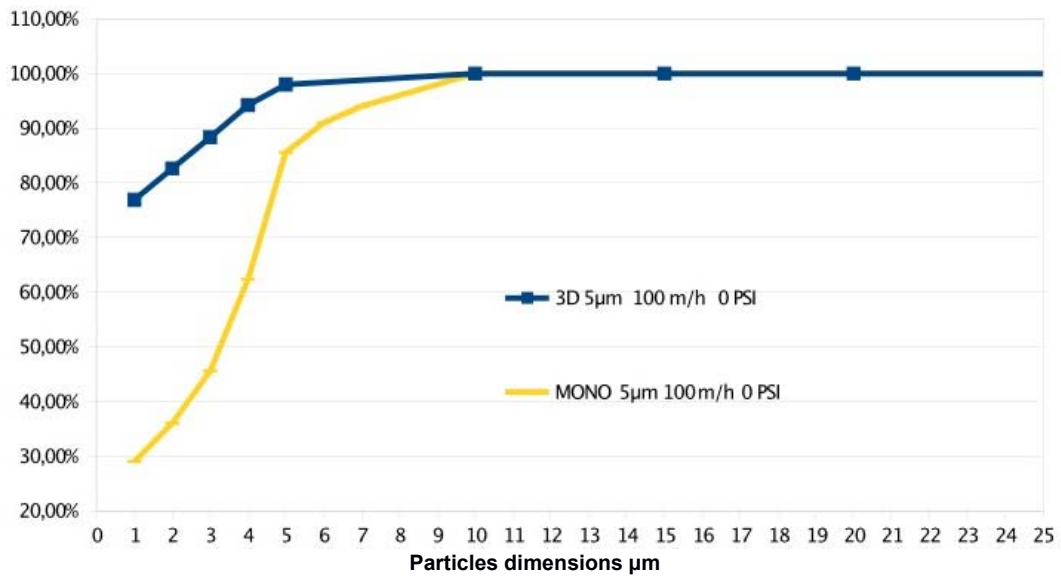

Comparison between 3D fabric , monofilament fabric with 10 micron filtration degree

FILTRATION EFFICIENCIES

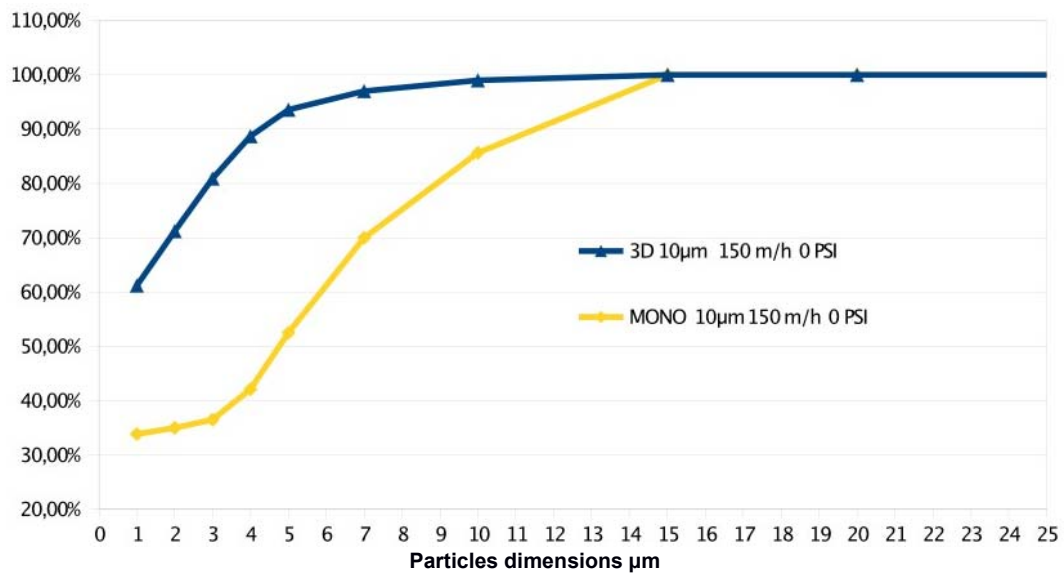

Comparison between 3D fabric , monofilament fabric with 20 micron filtration degree

FILTRATION EFFICIENCIES

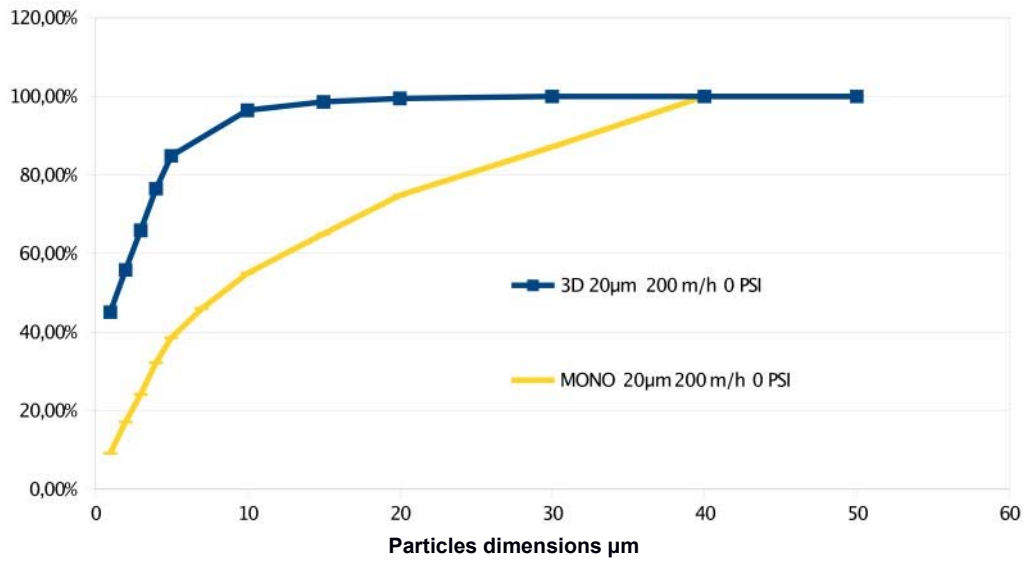

OPERATION

WORKS

Water enters the filter through the IN inlet and goes through the filtering cylinder (1) from the inside to the outside. This will retain all non-deformable suspended solids that are the same size or bigger than the filtration degree installed. Filtered water leaves through the outlet pipe (OUT).

REGENERATION

Constant deposit of suspended solid particles inside the filtering cylinder (1) obstructs the passage of water, causing a pressure differential (ΔP). At a preset ΔP value (ranging from 0.2 ÷ 0.4 Bar) an automatic cleaning cycle of the filtering (1) cylinder starts. This activity begins with a signal that opens the discharge valve (2) allowing communication of the suction nozzles (3) with the outside environment. At the same time, the electric motor's (4) rotary motion allows the nozzles to inspect the entire filtering surface. Dirt is removed through the discharge valve (2). The cleaning cycle lasts 15 sec.

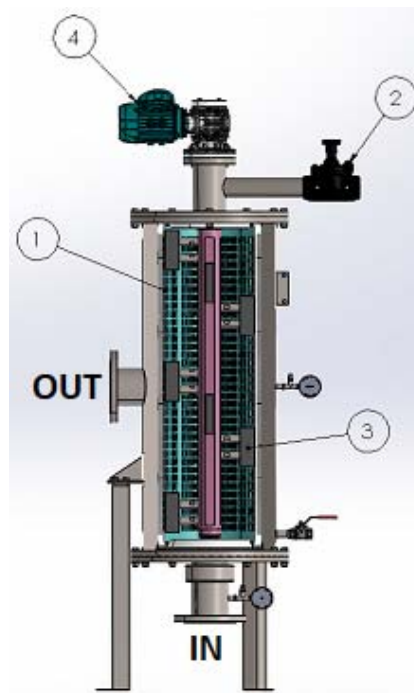

FILTER ELEMENT AND CLEANING SYSTEM

FILTRATION PHASE

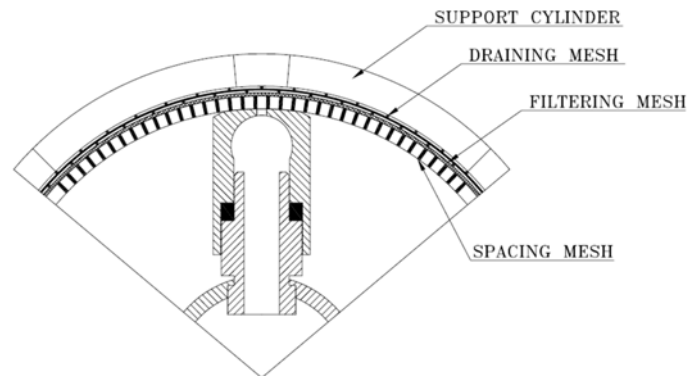

WASHING PHASE

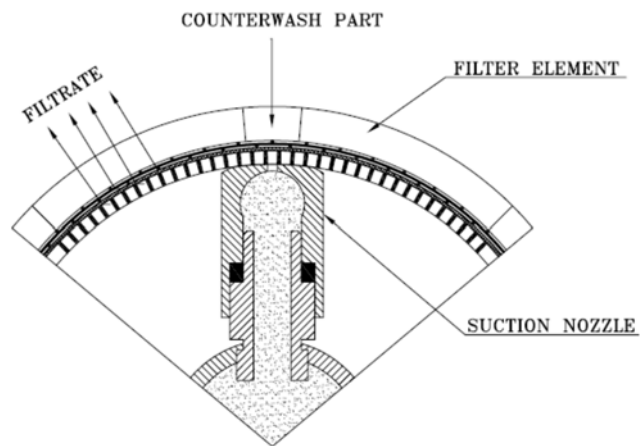

PICTURE OF FILTER INTERIOR



CONTROL

A switchboard controls the washing phases. The signal that starts the cleaning cycle is given by a differential pressure switch or by time. The switchboard gives an "alarm" signal in case of problems in the washing system. These signals can be sent to a pre-existing control centre. The washing phase can also be controlled manually. The solenoid controlling the valve is pneumatic.



DIMENSIONS AND TECHNICAL DATA SCR L M

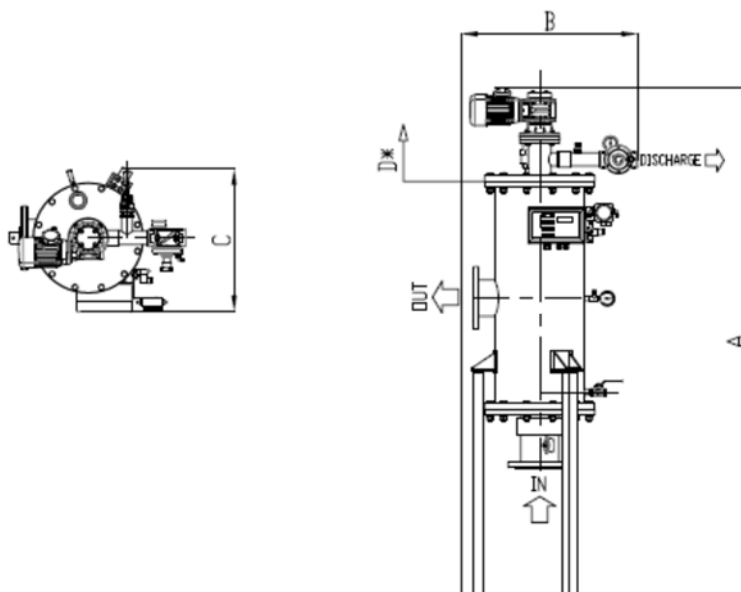

MODEL	SCR L M 10	SCR L M 30	SCR L M 65	SCR L M 90	SCR L M 130
Filtering area (cm ²)	1000	3000	6500	9000	13000
Connections- In/Out	2" BSP	DN80	DN80-DN100	DN100 – DN150	DN150-DN200
Exhaust connections	1"	2" F	2" F	2" F	2" F
Draining connections	1/2" F	1/2" F	1/2" F	1" F	1" F
1 Bar washing flow rate with mesh from 5 micron - m ³ /h	4	4	8	9	14
Wash duration - Sec.	20	20	20	20	20
Min-max pressure - Bar	1-10	1-10	1-10	1-10	1-10
Max Temperature - °C	50	50	50	50	50
Power supply - Volt	400 50/60 Hz	400 50/60 Hz	400 50/60 Hz	400 50/60 Hz	400 50/60 Hz
Power required - Watt	90	180	180	370	550
Solenoid valve - Volt/Watt	24 AC / 6	24 AC / 6	24 AC / 6	24 AC / 6	24 AC / 6
Pneumatic supply - Bar	2 - 8	2 - 8	2 - 8	2 - 8	2 - 8
Vessel rule	EN13445	EN13445	EN13445	EN13445	EN13445
Construction certificates	CE	CE	CE	CE	CE
Maximum size of inlet particles* - mm	0.2	0.2	0.2	0.2	0.2
* Max total suspended solids at inlet - 20 micron - mg/l	20	20	20	20	20
* Max total suspended solids at inlet - 10 micron - mg/l	10	10	10	10	10
* Max total suspended solids at inlet - 5 micron - mg/l	5	5	5	5	5
Foot	included	included	included	included	included
A (mm)	965	1420	1860	1830	2330
B (mm)	440	710	710	800	910
C (mm)	370	530	530	645	755
D (mm) Cartridge extraction	450	590	1030	1150	1650
WEIGHT when empty Kg	41	62	81	190	238
WEIGHT in operation Kg	52	103	157	325	523

DIMENSIONS AND TECHNICAL DATA SCR L O M

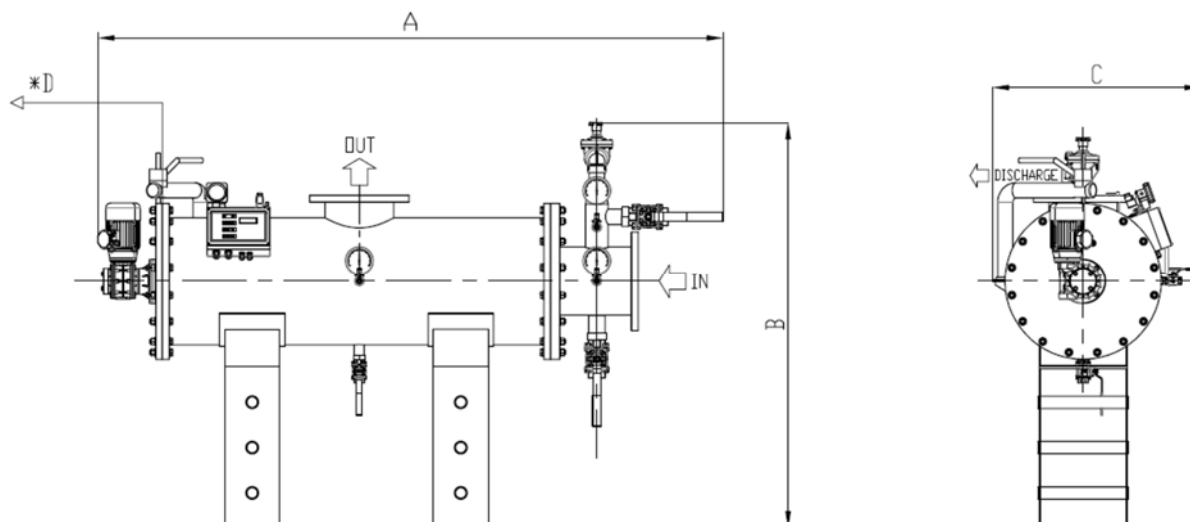

MODEL	SCR L M 65	SCR L M 90	SCR L M 130
Filtering area (cm ²)	6500	9000	13000
Connections- In/Out	DN80-DN100	DN100 – DN150	DN150-DN200
Exhaust connections	2" F	2" F	2" F
Draining connections	1/2" F	1" F	1" F
1 Bar washing flow rate with mesh from 5 micron - m ³ /h	8	9	14
Wash duration - Sec.	20	20	20
Min-max pressure - Bar	1-10	1-10	1-10
Max Temperature - °C	50	50	50
Power supply - Volt	400 50/60	400 50/60	400 50/60
	Hz	Hz	Hz
Power required - Watt	180	370	550
Solenoid valve - Volt/Watt	24 AC	24 AC	24 AC
	/ 6	/ 6	/ 6
Pneumatic supply - Bar	2 - 8	2 - 8	2 - 8
Vessel rule	EN13445	EN13445	EN13445
Construction certificates	CE	CE	CE
Maximum size of inlet particles* - mm	0.2	0.2	0.2
* Max total suspended solids at inlet - 20 micron - mg/l	20	20	20
* Max total suspended solids at inlet - 10 micron - mg/l	10	10	10
* Max total suspended solids at inlet - 5 micron - mg/l	5	5	5
Foot	included	included	included
A (mm)	1860	1930	2430
B (mm)	710	880	1050
C (mm)	530	645	755
D (mm) Cartridge extraction	1030	1150	1650
WEIGHT when empty Kg	81	190	238
WEIGHT in operation Kg	157	325	523

Technical Data are indicative and subject to change without notice

Correct calibration of the filter requires granulometric analysis, hardness, COD (Chemical Oxygen Demand) and BOD (Biochemical Oxygen Demand)

DESCRIPTION OF PARTS

PART	DESCRIPTION
Body - cover	AISI316 – SAF2205 – SAF2507
Connction flanges	AISI316 PN10
Mesh support strainer	PVC/ AISI316/PE
Suction nozzle	BRAL - PE
Nozzle support	AISI316 – SAF2205 – SAF2507
Nozzle pipe	AISI316 – SAF2205 – SAF2507
Internal seals	NBR – EPDM
Reduction unit	Aluminium and carbon steel
Electric motor	Hot-painted aluminium
Solenoid valve	Three-way aluminium
Electrical panel	ABS IP55 with front display
Differential pressure switch	Aluminium with parts in contact with liquid made of AISI 316
Discharge valve	PP diaphragm with flow rate regulation
Pressure gauges	Stainless steel with 2"1/2- 4" dial, radial connection and 0-10 Bar indication
Accessories (Plugs and adapters)	AISI316-PP-PVC – SAF2205

FILTERING MESH FLOW RATE TABLE (m³/h)

MODELLO	20 µm 3D AISI316	10 µm 3D AISI316	5 µm 3D AISI316
SCR L M 2-10	20	15	10
SCR L M 80-30	60	45	30
SCR L M 80/100-65	130	97	65
SCR L M 100/150-90	180	135	90
SCR L M 150/200-130	260	195	130

The flow rates indicated refer to a load loss of 0.2 Bar with clean, filtered water.

FILTER CODING TABLE

1 SHAPE / INSTALLATION FILTER	CODE
L / VERTICAL	SCRLM
L / HORIZONTAL	SCRLOM

3 BODY / COVER MATERIAL	CODE
AISI 316	0316
SAF2205 (DUPLEX)	2205
SAF2507 (SUPERDUPLEX)	2507

5 FILTER ELEMENT SIZE	CODE
10	010
30	030
65	065
90	090
130	130

8 NOZZLE SUPPORT MATERIAL	CODE
AISI316	1
SAF2205 (DUPLEX)	2
SAF2507 (SUPERDUPLEX)	3

10 PILOT DISCHARGE VALVE	CODE
PNEUMATIC	1

12 AUTOMATION	CODE
CONTROL PANEL + DIFF.SWITCH	C
NONE	0

2 APPLICATION	CODE
INDUSTRIAL	I

4 CONNECTION IN/OUT	CODE
2" BSP	002
DN80 PN10	080
DN100 PN10	100
DN150 PN10	150
DN200 PN10	200

6 MATERIALE CESTELLO	CODICE
PVC-U	1

7 FILTERING FABRIC MATERIAL	CODE
AISI316 3D	1

9 NOZZLE PIPE MATERIAL	CODE
AISI316	1
SAF2205 (DUPLEX)	2
SAF2507 (SUPERDUPLEX)	3

11 FILTRATION DEGREE	CODE
20	20
10	10
5	05

STANDARD VERSION