



SPRAY NOZZLE SELF CLEANING FILTER SERIES US



MAIN TECHNICAL CHARACTERISTICS:

- Filtration degree from 2000 to 25 μm on polyester mesh/ AISI316
- Minimum quantity of water at discharge

APPLICAZIONI

- Pre-filtration in UF systems
- Evaporation towers
- Heat exchangers
- In any situation where the fluid contains fibers

Ver.2022 Rev01

ELFI srl

Via Scodoncello 41/E 43044 Collecchio (PR)
Tel 0521806846

OPERATION

WORK

Water enters the filter through the (1) inlet and goes through the filtering cylinder from the inside to the outside. This will retain all suspended solids that are the same size or bigger than the filtration degree installed. Filtered water leaves through the outlet pipe (2).

RIGENERATION

When the differential pressure gauge reaches the pre-set pressure difference between filter inflow and outflow, a signal is triggered and the cleaning starts. This operation is divided into three separate phases:

The first phase is the closure of the inlet valve (1) with consequent closure of the outflow check valve (2).

In the second phase the vessel is emptied through the discharge valve (3)

The third phase is the actual cleaning: the washing inlet valve opens (4) and through the manifold (5) feeds the nozzles (6), at the same time the electric motor (7) powers the rotations of the cleaning systems. The washing pressure range from a minimum of 2 Bar to maximum of 10 Bar. Average length of the cleaning cycle is 120 sec.

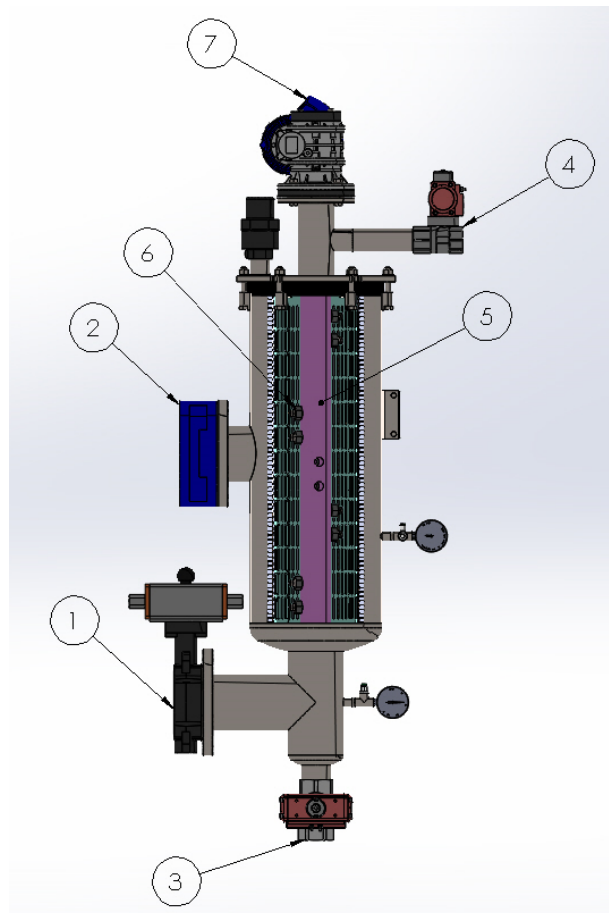

CONTROL

A switchboard controls the washing phases. The signal that starts the cleaning cycle is given by a differential pressure switch or by time. The switchboard gives an "alarm" signal in case of problems in the washing system. These signals can be sent to a pre-existing control center. The washing phase can also be controlled manually. The solenoids controlling the valves are pneumatic.



DIMENSIONS AND TECHNICAL DATA SCR L

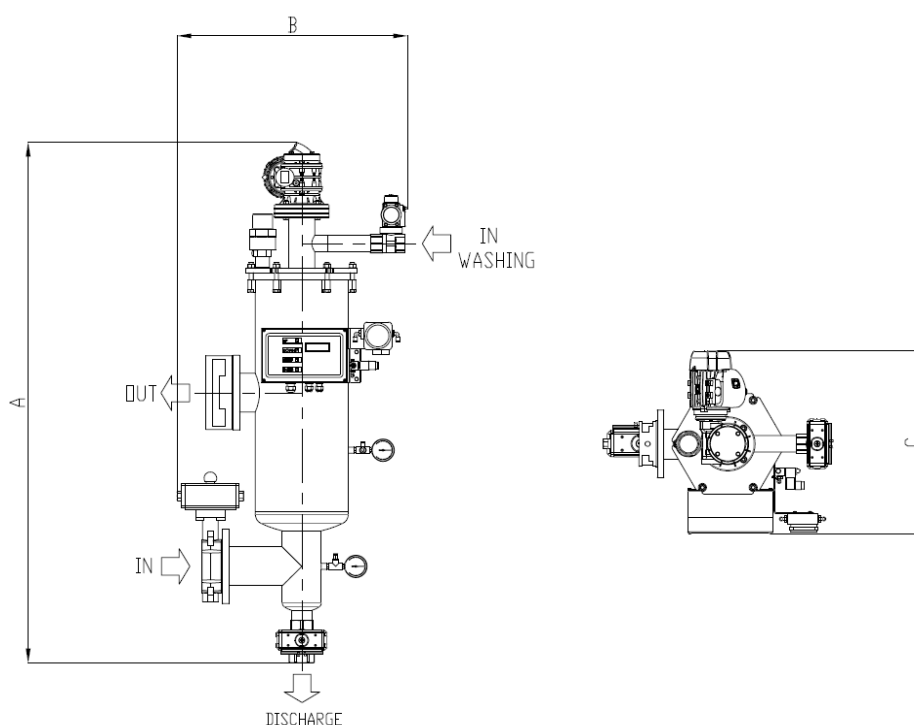

MODEL	US 15	US 30	US 45	US 60	US 90
Filtration area (cm ²)	1500	3000	4500	6000	9000
Connection In/Out	DN80	DN80	DN100	DN100	DN150
Connection Discharge	1"1/2 F	2" F	2" F	2" F	DN80
Connection Washing inlet	1" F	1"1/2 F	1"1/2 F	1"1/2 F	1"1/2 F
Washing flow rate at 3 Bar – m ³ /h	2	2	3	3.5	5
Wash duration - Sec.	80	80	80	80	80
Min-max pressure - Bar	0,5-10	0,5-10	0,5-10	0,5-10	0,5-10
Max Temperature* - °C	50	50	50	50	50
Power supply – Volt	400	400	400	400	400
	50/60	50/60	50/60	50/60	50/60
	Hz	Hz	Hz	Hz	Hz
Power required - Watt	90	180	180	180	370
Electric valve – Volt /Watt	24 AC	24 AC	24 AC	24 AC	24 AC
	/ 6	/ 6	/ 6	/ 6	/ 6
Pneumatic supply - Bar Bar	2 - 8	2 - 8	2 - 8	2 - 8	2 - 8
Construction certificates	CE	CE	CE	CE	CE
Maximum size of inlet particles - mm	5	5	5	5	5
Max total suspended solids at inlet - 120 micron - mg/l	20	20	20	20	20
A (mm)	1025	1190	1440	1440	1690
B (mm)	455	580	580	630	715
C (mm)	460	570	570	620	705
D (mm) Cartridge extraction	600	640	885	885	1160
Weight when empty Kg	44	66	51	62	75
Weight in operation Kg	55	98	83	106	133

*upon request 85°C

DESCRIPTION OF PARTS

COMPONENTE	DESCRIZIONE
Body	AISI316 – SAF2205 – SAF2507
Cover	AISI316 – SAF2205 – SAF2507
Connection threading	BSP
Flange connection	EN 1092-1 PN10
Mesh support strainer	PVC – AISI316
Filtering mesh	Polyestere - AISI316 da:500,300,200,125,80,50,25 µm
Spray nozzle	PVDF
Nozzle pipe	PVC – AISI316
Internal seals	EPDM
Reduction unit	Aluminium and carbon steel
Electric motor	Hot-painted aluminium
Solenoid valve	Three-way aluminium
Switchboard	ABS IP55 with front display
Differential pressure switch	Aluminium with parts in contact with liquid made of AISI 316
Butterfly valve	AISI316 with pneumatic actuator
Ball valve	AISI316 with pneumatic actuator
Vent	PA automatic
Accessories	PVC- AISI316

FILTER CODING TABLE

1 SHAPE / INSTALLATION FILTER	CODE
L / VERTICAL	US L

3 BODY / COVER MATERIAL	CODE
AISI 316	0316
SAF2205 (DUPLEX)	2205
SAF2507 (SUPERDUPLEX)	2507

5 FILTER ELEMENT SIZE	CODE
15	15
30	30
45	45
60	60
90	90

9 PILOT DISCHARGE VALVE	CODE
PNEUMATICA	1

11 AUTOMATION	CODE
CONTROL PANEL + DIFF.SWITCH	C
NONE	0

STANDARD VERSION

2 APPLICATION	CODE
INDUSTRIAL	I

4 CONNECTION IN/OUT	CODE
DN80 PN10	080
DN100 PN10	100
DN150 PN10	150

6 BASKET MATERIAL	CODE
AISI316	1
AISI904	2

7 FILTERING FABRIC MATERIAL	CODE
AISI316	1
AISI904	2

8 NOZZLE PIPE MATERIAL	CODE
PVC-U (15-30-45)	1
AISI316 (60-90)	2
PVC-C	3
SAF2205 (DUPLEX)	4
SAF2507 (SUPERDUPLEX)	5

10 FILTRATION DEGREE	CODE
300	0300
200	0200
120	0120
80	0080
50	0050
25	0025